

Compressor

MacGregor Water-cooled piston compressor W55, W80, W110, W140



Structural features

- Two staged, vertical construction with one cylinder differential piston, exchangeable, dry cylinder liners

Valves

- 1st stage: Combined suction and pressure valve
- W55 - 2nd stage: 1 suction and pressure valve each
- W80, W110, W140 - 2nd stage: combined suction and pressure valves

Water cooling

- Intercooler and aftercooler

Splash lubrication W55

- Oil level inspection glass

Force feed lubrication W80, W110, W140

- Gear pump directly driven by the crankshaft
- Oil pressure control by means of pressure gauge and pressure switch
- Oil level inspection glass
- Crankcase venting through vent filter on oil filler
- Lubrication of 1st stage by means of dosing pump with sight glass at the cylinders

Bearings

- W55: crankshaft: ball bearings
- W80, W110, W140: slide bearings
- Connecting rod: slide bearings
- Wrist pin: slide bearings

Technical data

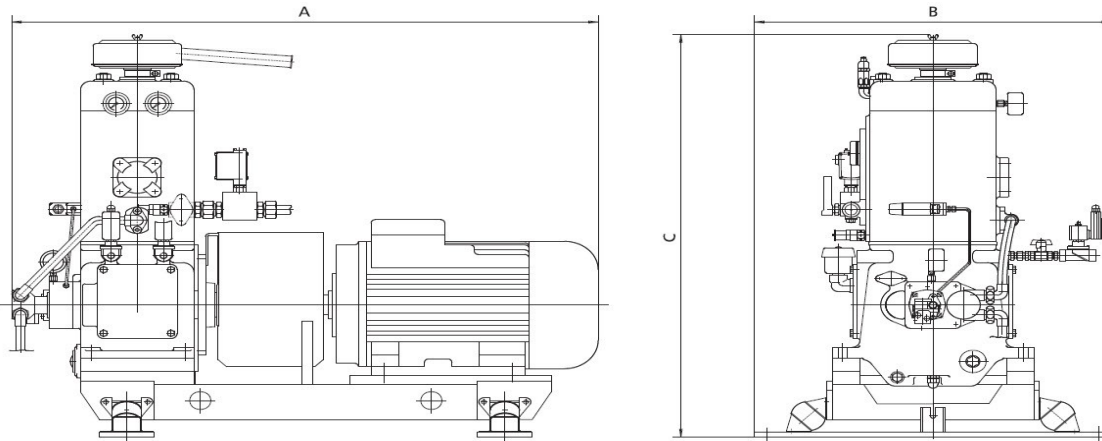

Type	Cylinders	Stage	Speed r.p.m.	F.A.D m³/h	Power kW	Weight incl. e-motor approx. kg	Dimensions		
							A	B	C
W55	1	2	1150	42	10	400	945	600	950
			1450	53	13	400	945	600	950
			1750	63	16	400	945	600	950
W80	1	2	1150	63	14.5	550	1265	820	1055
			1450	80	18	550	1227	820	1055
			1750	93	22.5	550	1265	820	1055
W110	1	2	1150	83	17	700	1349	850	1130
			1450	106	23	700	1349	850	1130
			1750	130	29	750	1411	850	1130
W140	1	2	1150	115	24.5	750	1411	850	1130
			1450	145	32	850	1439	850	1170

All data apply to a final pressure of 30 bar. The right for alteration of specification and data to incorporate improvements in design is reserved.

- Motor ①
- Flywheel and coupling ②
- Solenoid valve for draining ③
- Non-return valve ④
- Pressure switch ⑤
- Oil and water separator ⑥
- Flexible hoses ⑦
- Cooling water temperature control switch ⑧

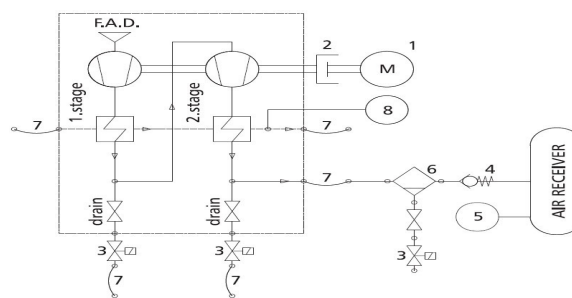

Wherever needed, you can rely on our support.
 We serve our customers globally:

- Ankerløkken Marine
- Allset
- ASCA
- Becker
- BMH
- Conver-OSR
- Grampian Hydraulics
- Flintstone
- Greer Marine
- Hamworthy
- Hatlapa
- Hydramarine
- Hägglunds
- Interschalt
- KGW
- KYB - ASCA
- KYB - Kayaba Industries / Navire Cargo Gear
- Luezhoe
- MacGregor
- MacGregor-Conver
- MacGregor-Hägglunds
- MacGregor-Kayaba
- MacGregor-Navire
- Navire Cargo Gear
- NMF
- Nordströms
- Ozean Service & Reparatur
- Platform Crane Services (PCS)
- Plimsoll
- Pusnes
- Porsgrunn
- Rapp
- Triplex
- TTS
- Vestnorsk Hydraulikkservice (VNH)

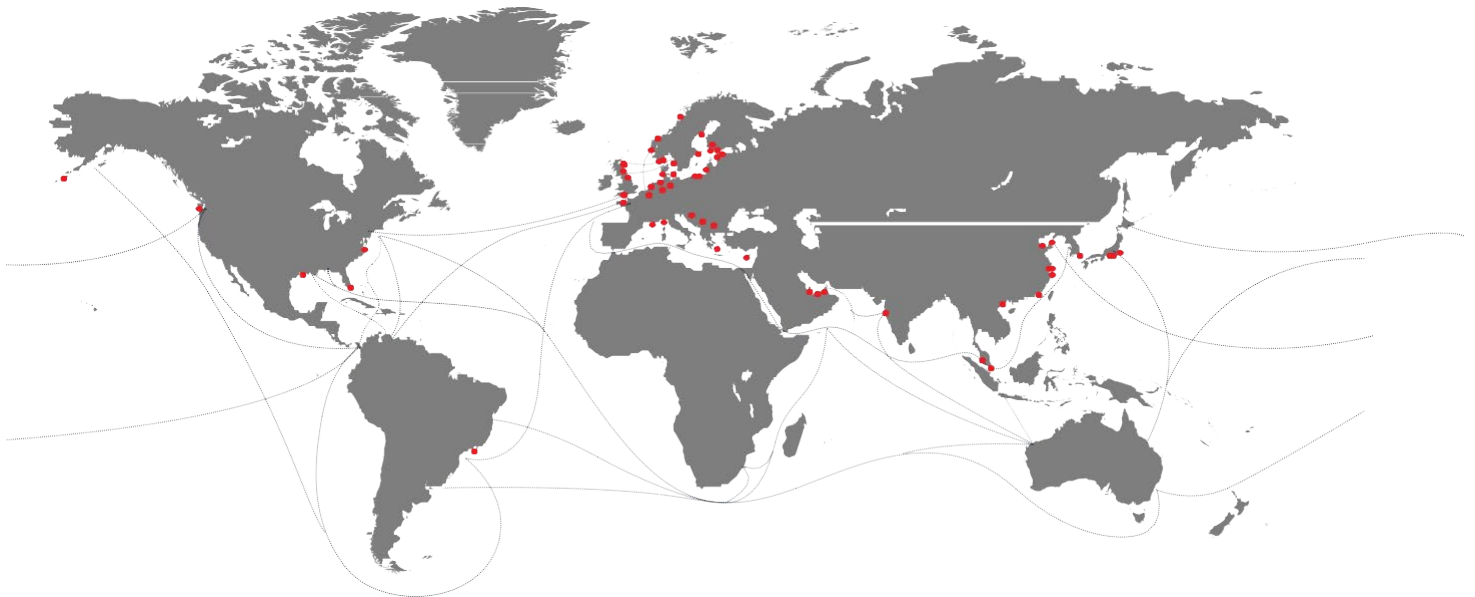

MacGregor is a leader in sustainable maritime cargo and load handling with a strong portfolio of products, services and solutions, all designed to perform with the sea.

Shipbuilders, shipowners and operators are able to optimise the lifetime profitability, safety, reliability and environmental sustainability of their operations by working in close cooperation with MacGregor.

MacGregor is part of Cargotec (Nasdaq Helsinki: CGCBV).

Published by MacGregor. Copyright © MacGregor May 2024. All rights reserved. No part of this publication may be reproduced, stored, photocopied, recorded or transmitted without permission of the copyright owner.

