

# Steering gear pump exchange/overhaul programme

Enhancing the safety and reliability of your equipment

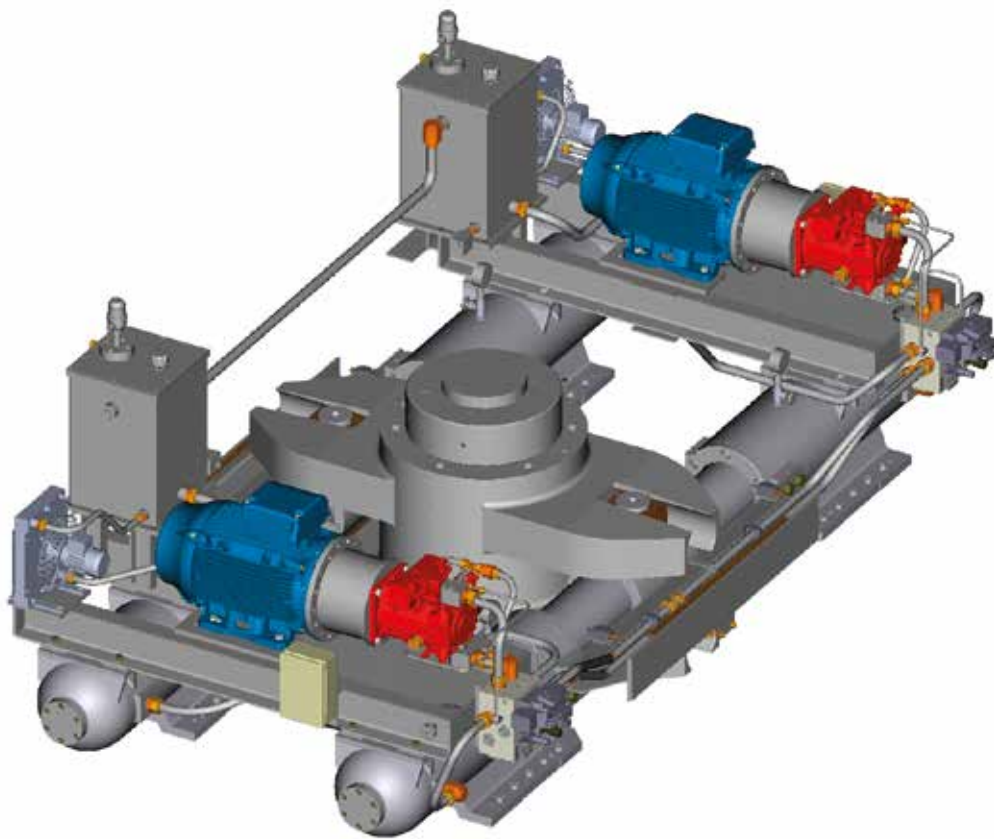

At your service



**MACGREGOR**

Designed to perform with the sea

# Steering gear pump exchange/overhaul programme

**MacGregor customers can now benefit from an exclusive steering gear pump exchange and/or overhaul programme that offers:**

- 50% credit on an exchange/overhaul basis for (A4VG+A2P) pumps
- 25% discount on all other steering gear pumps

Our steering gear pumps are thoroughly tested, inspected and delivered with a MacGregor guarantee and extensive support from our global service network.

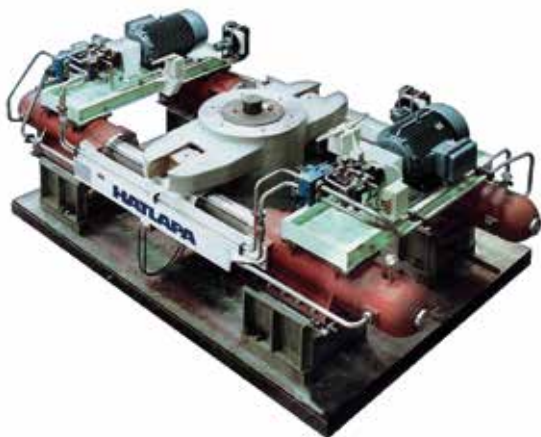
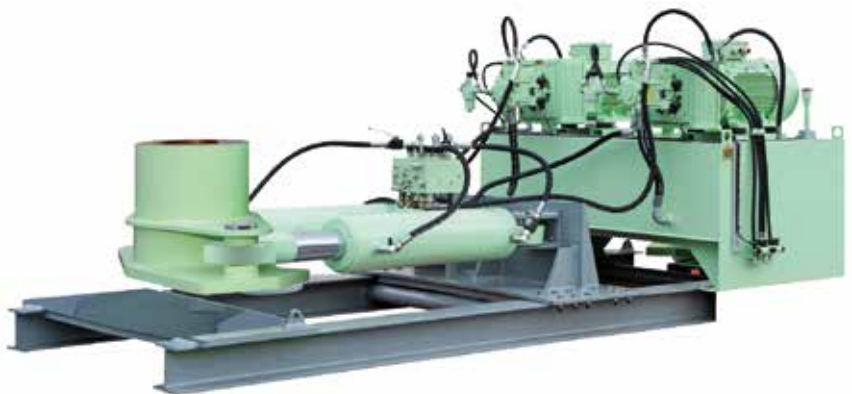

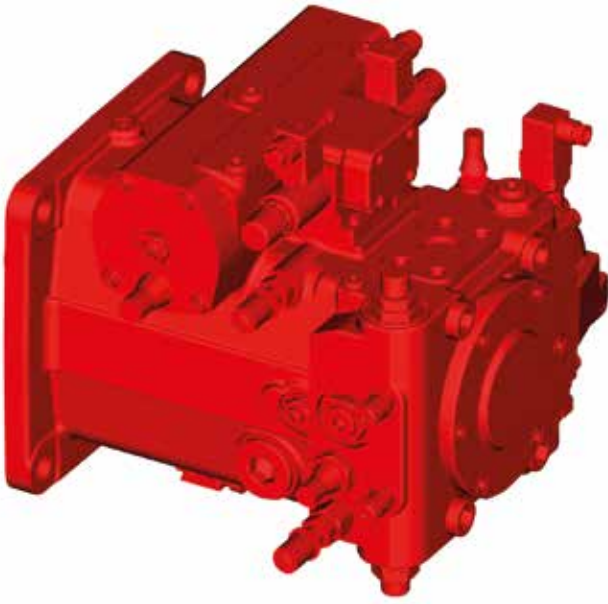

## Safety

Hydraulic pumps need constant condition monitoring and visual inspection to ensure their safe operation. It is extremely important to check and observe them on a regular basis to see how the pumps perform during operation. Overhauling the pumps on board is not always practical, therefore MacGregor has developed an effective solution to keep equipment safe and in good working condition.

Pumps are exposed to heavy loads and a corrosive marine environment. Other elements that cause issues include:

- Fluid contamination
- Foreign bodies
- Leaks

## How does the MacGregor pump exchange programme work?

### For A4VG+A2P and Hatlapa pumps:

- You order the pump as you would do normally, but you send the old pump to our warehouse
- You will then receive a credit note, cutting the final costs of the original pump by 50%
- In case the pumps cannot be overhauled, you will receive a new pump for the exchange price (A4VG+A2P)

## How does the MacGregor overhaul programme work?

### For A4VG+A2P and Hatlapa pumps:

- You send the pump for overhaul to our warehouse
- When the pumps cannot be overhauled, you will receive a new pump for the exchange price (A4VG+A2P)
- The overhaul price is half the price of a new pump

### Other steering gear pumps:

- When you order a new pump, you receive a 25% discount on the price of a new pump

## General information related to all programmes:

- Delivered with a MacGregor guarantee and 12 months of overhauled/new pumps
- Transportation and packaging costs are covered by the customer
- Transportation and packaging costs are excluded from the discount offer
- Special prices for all rotex gear rims (for coupling) are included in each quotation
- All other discount offers are excluded from this exclusive programme

## Why choose a MacGregor (OEM) pump exchange/overhaul programme for your steering gear?

- Short delivery times
- A 50% price reduction compared with buying a new pump (A4VG & A2P pumps)
- For all other steering gear pumps, we offer a 25% discount on new pumps
- Enhanced operational availability and safety for your steering gear
- Tested and proven applications
- 24/7 support from MacGregor's global service network

## Ordering

Please contact your MacGregor account manager or send an email to: [spares.cx@macgregor.com](mailto:spares.cx@macgregor.com). When placing your order, please state the IMO number of the vessel and the serial number of the steering gear.

Wherever needed, you can rely on our support.  
We serve our customers globally:

- Ankerløkken Marine
- Allset
- ASCA
- Becker
- BMH
- Conver-OSR
- Grampian Hydraulics
- Flintstone
- Greer Marine
- Hamworthy
- Hatlapa
- Hydramarine
- Hägglunds
- Interschalt
- KGW
- KYB - ASCA
- KYB - Kayaba Industries / Navire Cargo Gear
- Luezhoe
- MacGregor
- MacGregor-Conver
- MacGregor-Hägglunds
- MacGregor-Kayaba
- MacGregor-Navire
- Navire Cargo Gear
- NMF
- Nordströms
- Ozean Service & Reparatur
- Platform Crane Services (PCS)
- Plimsoll
- Pusnes
- Porsgrunn
- Rapp
- Triplex
- TTS
- Vestnorsk Hydraulikkservice (VNH)

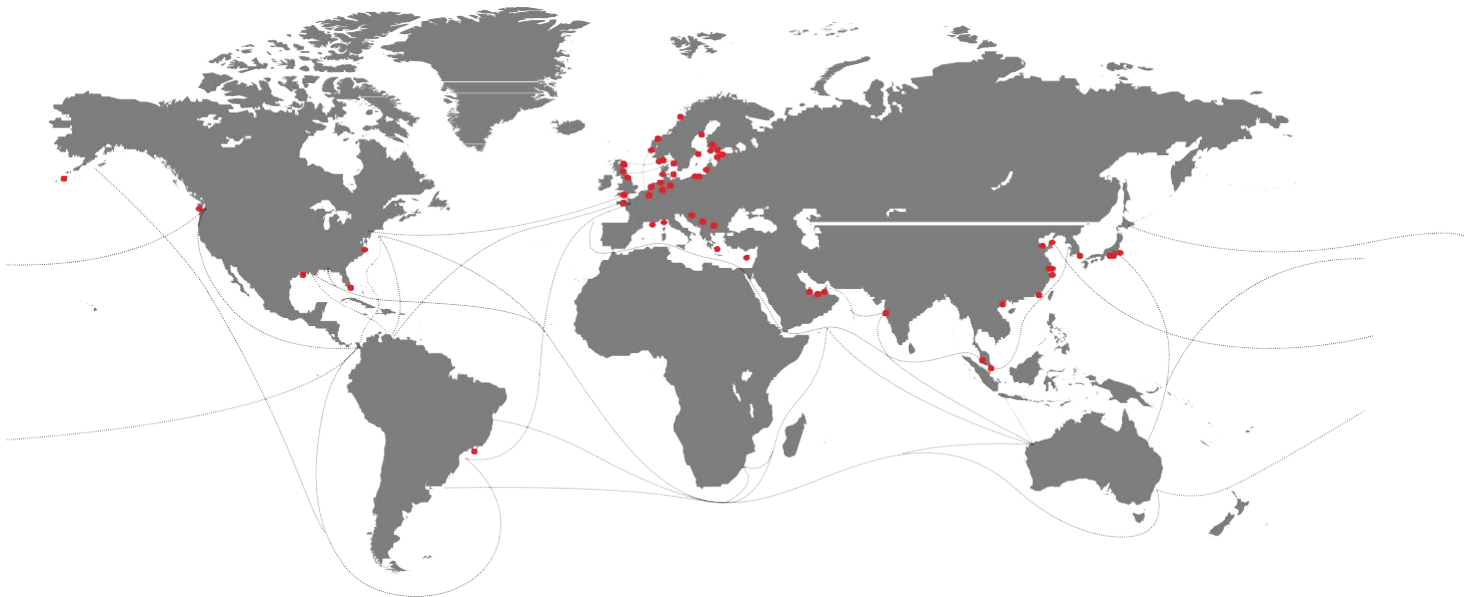

MacGregor is a leader in sustainable maritime cargo and load handling with a strong portfolio of products, services and solutions, all designed to perform with the sea.

Shipbuilders, shipowners and operators are able to optimise the lifetime profitability, safety, reliability and environmental sustainability of their operations by working in close cooperation with MacGregor.

MacGregor is part of Cargotec (Nasdaq Helsinki: CGCBV).

Published by MacGregor. Copyright © MacGregor May 2024. All rights reserved. No part of this publication may be reproduced, stored, photocopied, recorded or transmitted without permission of the copyright owner.

